

# Forward “C” Deck Machinery Room on *Titanic*

---

By Bob Read, D.M.D.

## Introduction

Questions are frequently asked regarding the equipment contained in the machinery room of *Titanic*'s forward “C” (shelter) deck which is located directly under anchor handling and mooring equipment on the forecastle deck. The information about specifics is out there but it is somewhat difficult to locate. No comprehensive drawings of this equipment are known to exist. This article will attempt to draw together various sources to attempt to draw representations of the equipment as accurately as possible.

## Sources of Evidence

Much of the information that we have about the equipment in the machinery room is seen in very simplified drawings on general arrangement plans as seen in Figure 1.

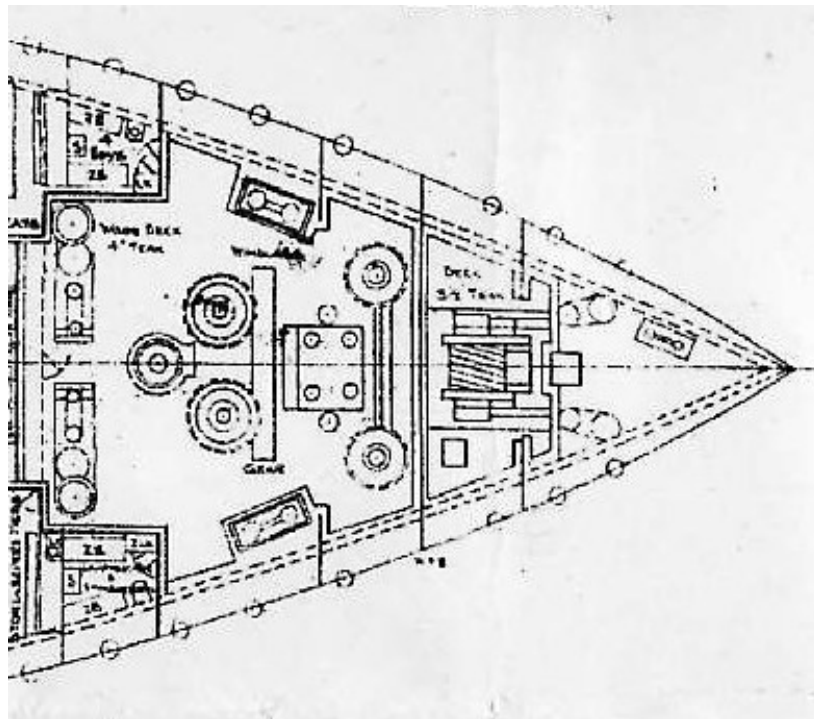

Figure 1

Simplified plan of *Olympic*'s “C” deck machinery room

The most precise description of the equipment is found in the Engineering journal about *Britannic* (Vol. XCVII – From January to June, 1914).

The section from Engineering describing the equipment is quoted here:

**“The windlass and warping gear is of the well-known design of Messrs. Napier Brothers, Limited, Glasgow. The anchor gears consist of two cable-holders mounted on the forecastle head and driven from the deck below by two 18-in. by 14-in. double cylinder engines through worm gearing, the engines being coupled in such a way that either or both can be connected to one of other of the cable holders. In addition to this gear there is a wire-rope windlass for working the auxiliary 15-ton anchor which is fitted on the shelter-deck forward of the engines and driven by them through bevel and worm gearing. This wire-rope windlass has a grooved barrel 7 ft. 8 in. in diameter by 8 ft. 7 in. long, and is capable of taking 175 fathoms of 10 in. [ 3 inches diameter] steel wire rope. The brake-gear of the cable holders and wire-rope drum is of Napier’s patent differential self-holding type, the special virtue of which is that it is the load which governs the grip, so that once the brake is put in gear, it can be safely left alone no matter how bad the weather may get, as the greater the strain on the cable the tighter the latter is held.**

**The forward warping-gear consists of four capstans on the forecastle head, two of which are driven from the deck below by separate 18-in. by 14-in. double-cylinder engines through spur and bevel-wheel gearing. The other two are connected to the windlass engines by bevel gearing. There is also an additional capstan on the shelter-deck aft of the windlass engines, connected to them by bevel gearing.”**

**“The gears throughout are so designed as to ensure an ample margin of strength, and are the result of Messrs. Napier’s experience, extending over half a century. Cast steel is used wherever possible, and the worm-wheel rims are of gun-metal. All the gear wheels are machine cut; this has been the firm’s practice for the last thirty years.”**

Dimensions of much of the equipment is found in the Oct. 6, 1899 issue of Engineering journal covering the equipment of S.S. *Oceanic*. There are some aspects described in the *Britannic* article which are different than the *Oceanic* equipment. Later plans of Napier Brothers equipment was used such as those found in the Shipbuilder covering S.S. *Lusitania*.

No surviving photos of this equipment on any of the *Olympic* class ships is known to exist except for a photo taken while *Olympic* was being scrapped. For that matter, no photos of the anchor-handling and warping engines and equipment was found.

The following drawings of the “C” (shelter) deck were produced by synthesizing all the sources listed above. I am not claiming that these drawings are exact representations of the equipment. Many of the details had to be determined by logical deduction.

[Go to next page](#)

Figure 2 is a plan view of the forecastle deck anchor-handling and warping equipment.

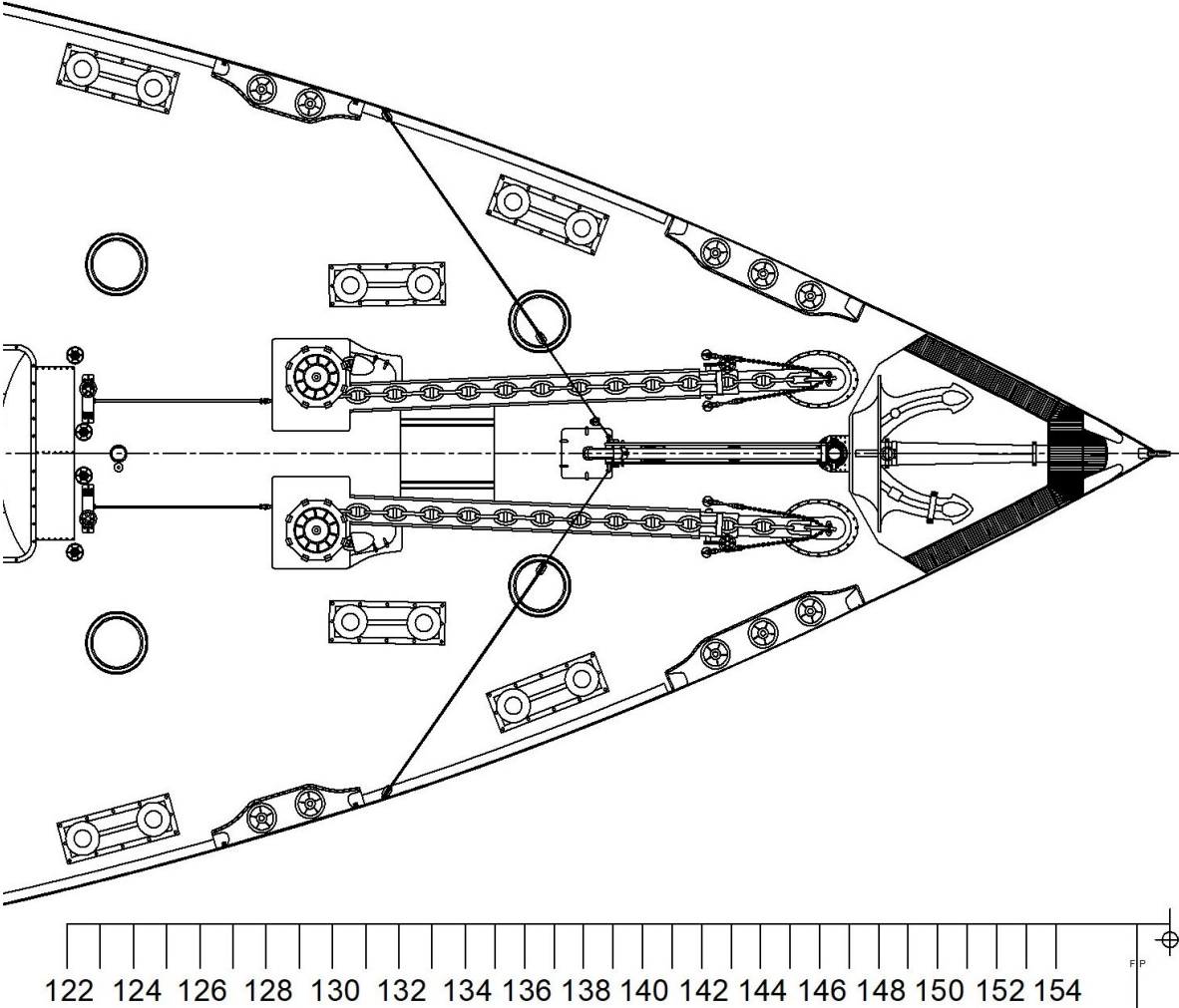

Figure 2

Plan view of forecastle anchor-handling and warping equipment

[link to high resolution version of Figure 2](#)

Go to next page

Figure 3 is a plan view of the forward "C" (shelter) deck machinery room.

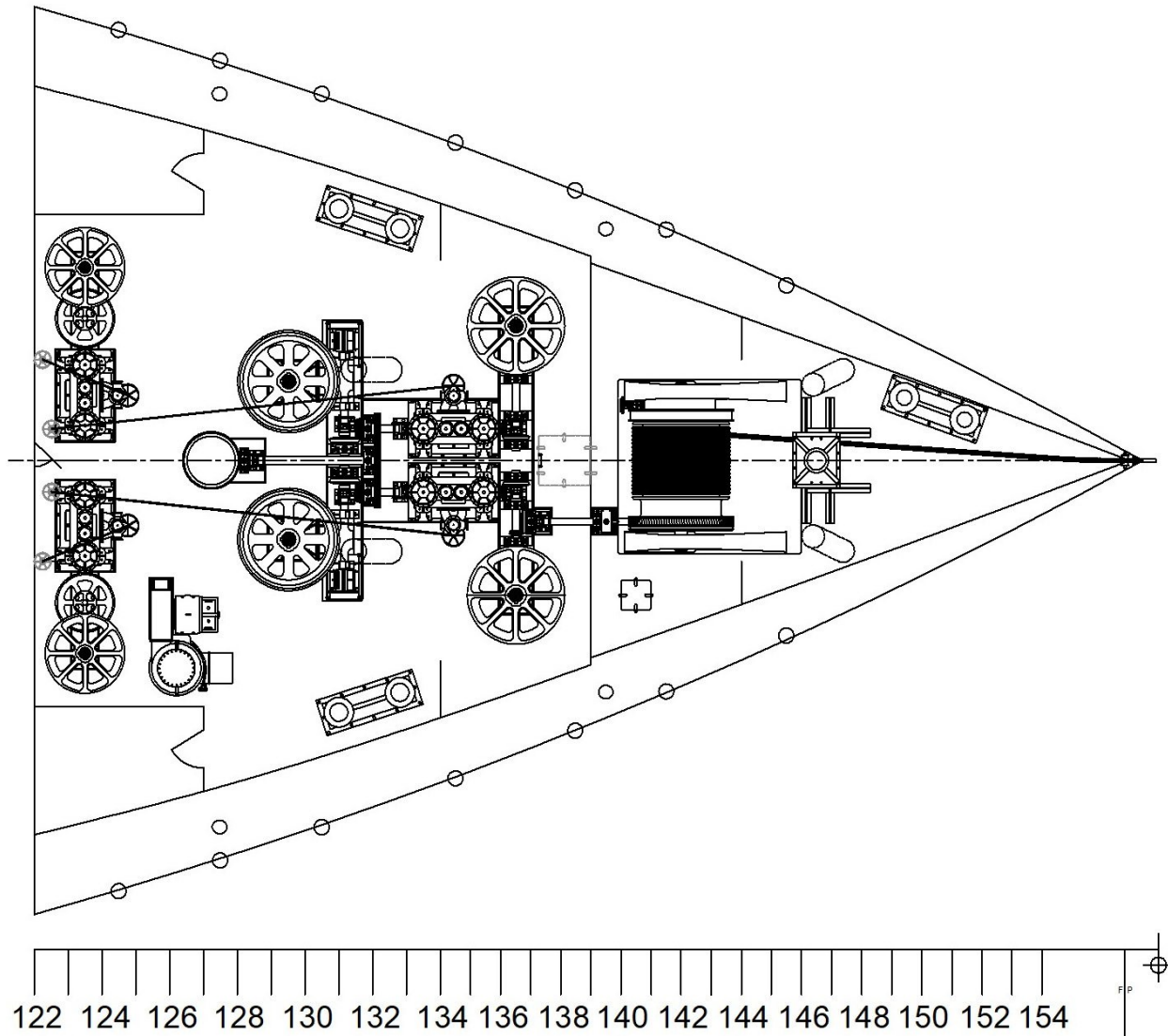

Figure 3

Plan view of forward "C" (shelter) deck machinery room

[link to high resolution version of Figure 3](#)

Go to next page

Figure 4 is identical to Figure 3 except that it is annotated.

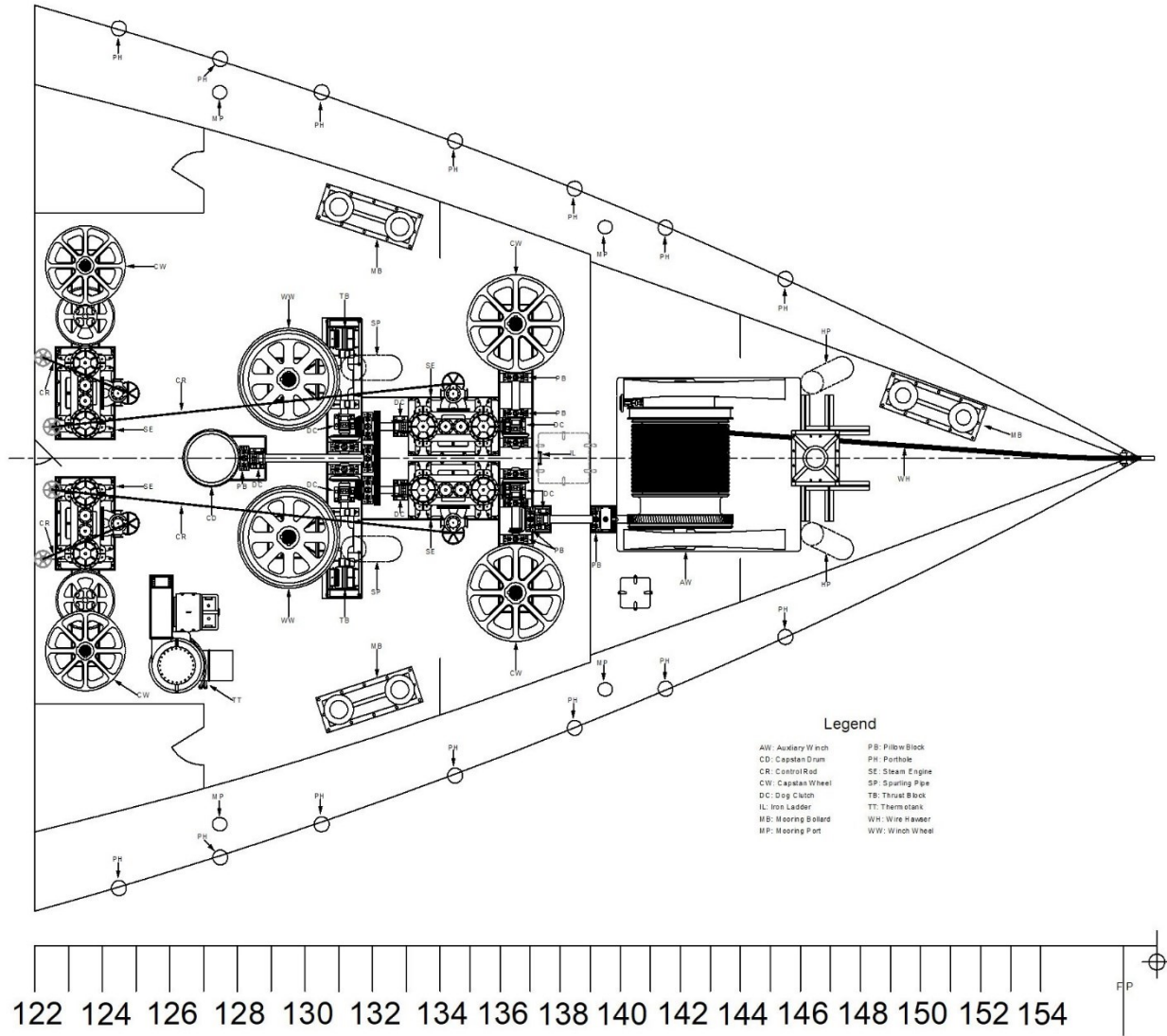

Figure 4

Annotated version of Figure 3

[link to high resolution of Figure 4](#)

Go to next page

Figure 5 is a starboard elevation view of forward “C” (shelter) deck machinery room.

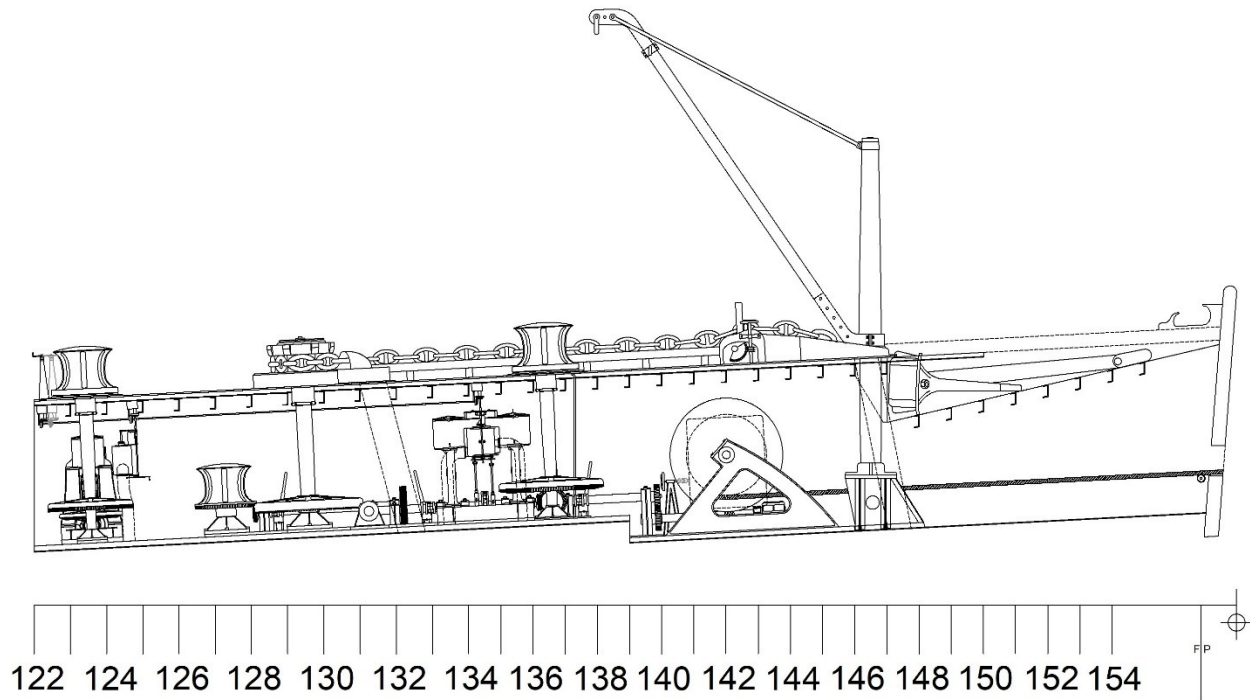

Figure 5

Starboard elevation of forward “C” (shelter) deck machinery room

[high resolution version of Figure 5](#)

## Steam Engines

The steam engines utilized in the machinery room were manufactured and installed by Messrs. Napier Brothers. There were four identical engines in the forward “C” (shelter) deck machinery room. These were double cylinder engines with piston diameter of 18 in. and a stroke of 14 in. The engines sat on steel bed with a raised perimeter edges to contain any oil spills from the engine. The design of these engines changed very little over the years. Figure 6 shows one of the Napier engines

Go to next page

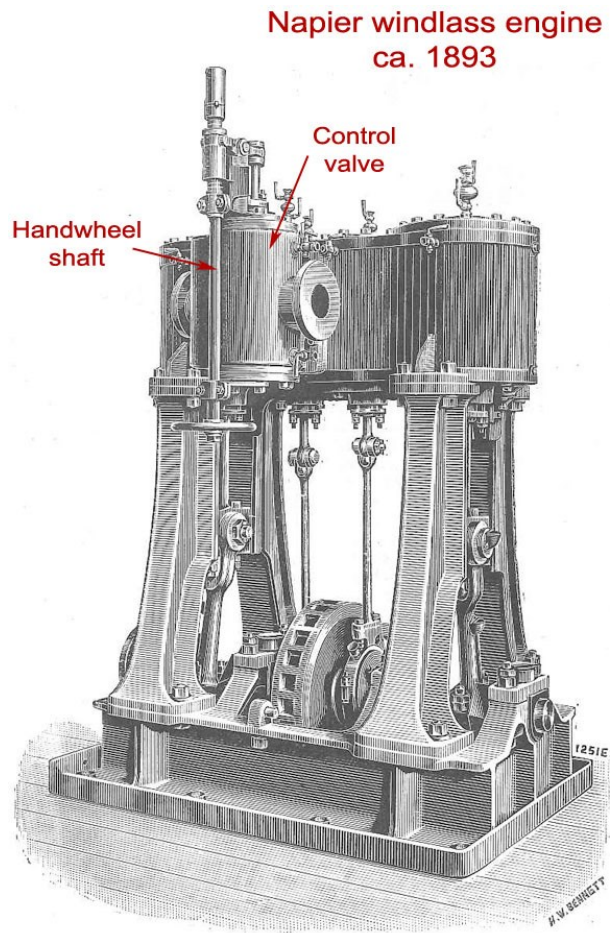

Figure 6

Napier windlass engine

## Gears

The gearing to the machinery was described in the *Britannic Engineering* journal excerpt from 1914 quoted above. Some of the readers may not be familiar with the types of gears described. They are shown in Figure 7.

Go to next page



bevel gears

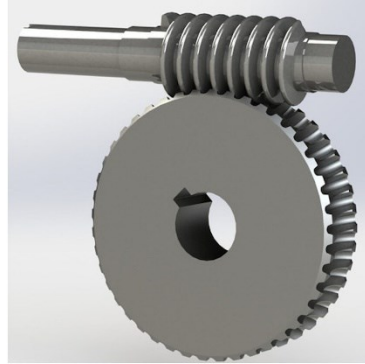

worm gears



spur gears

Figure 7

### Gear types

There is gearing that I don't believe is described in the Engineering article. Forward of frame #139F the steel deck is 16 inches lower than aft of #139F. To compensate for this difference in deck heights I believe that they employed a pair of spur gears so that the drive shaft to the auxiliary winch forward was the same height off the deck as the various drive shafts aft of frame #139F.

A second area where there was additional gearing was just aft of the steam engines which drove the windlasses. The Engineering article states **“the engines being coupled in such a way that either or both can be connected to one of other of the cable holders”**. The article calls what we have come to call the windlasses on the forecastle deck “cable holders”. The gearing to allow one or both engines to drive a single windlass on the forecastle is accomplished by a set of three spur gears. There would have been one spur gear on each drive shaft of the two windlass engines. Between them they were connected by a third spur gear. This allowed both engines to turn in the same direction. Additionally, the center spur gear drove the capstan which was located on the centerline of “C” (shelter) deck.

### Clutches

In order to isolate different pieces of equipment from driveshaft power, “dog clutches” were strategically placed. A “dog clutch” is a type of clutch that couples two rotating shafts or other rotating components not by friction but by interference or clearance fit. Figure 8 is an example of a dog clutch. When the power from the drive shaft is disconnected by the dog clutch, the clutch is said to be engaged. When the power from the drive shaft is connected by the dog clutch, the clutch is said to be disengaged. Figure 8 show an example of a dog clutch.

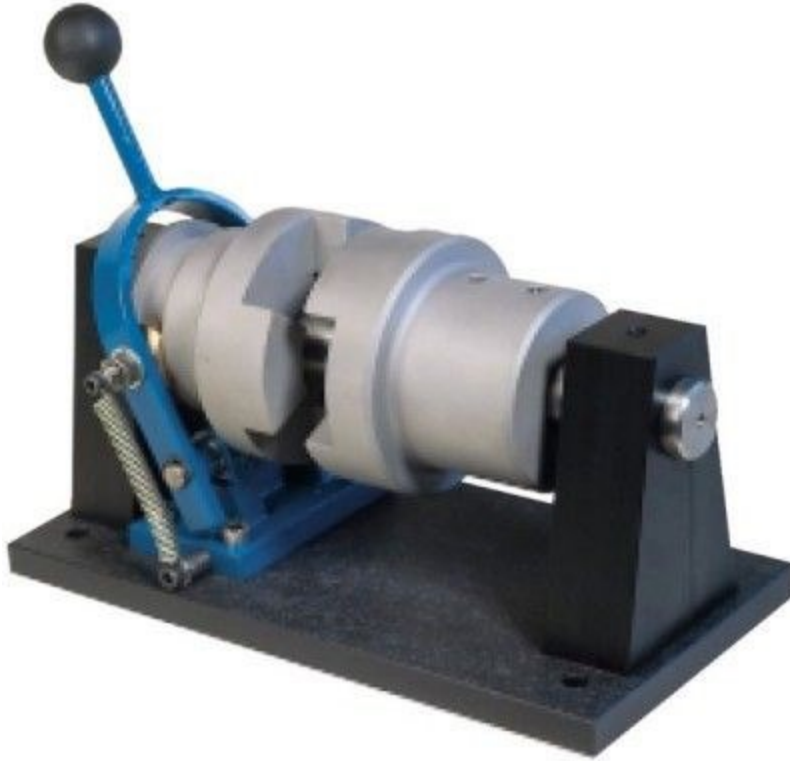

Figure 8

Dog clutch

## Bearing Blocks

The various drive shafts which drove the equipment had two types of bearing blocks. The first is a “pillow block”. A pillow block usually refers to a housing with an included anti-friction bearing, wherein the mounted shaft is in a parallel plane to the mounting surface. These pillow block bearings were placed along the steel track over which the drive shafts were located. The steel tracks allowed the bearings to be mounted for precision operation with the drive shafts. The tracks also had raised edges to contain any oil. Figure 9 shows a type of pillow block

Go to next page



Figure 9

### Pillow block

The second type of bearing block used in the machinery room was a “thrust block”. These were employed at the end of shafts to anchor cable windlasses and the auxiliary windlass. Their purpose was to minimize the movement of the shaft in the direction of its travel. The great forces applied to the windlasses and the heavy resistance caused forces which would otherwise would result in “endplay” of the drive shaft. These thrust bearings resisted such forces. Figure 10 shows an illustration of a thrust block.

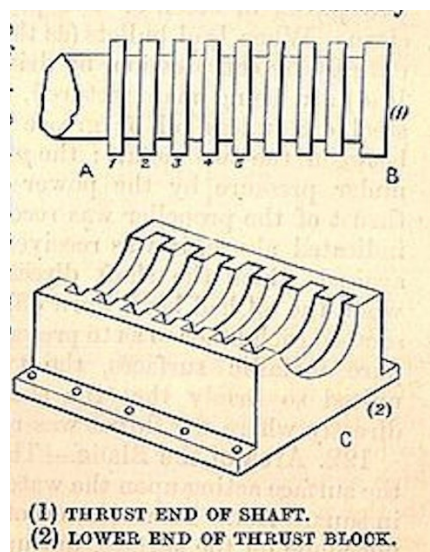

Figure 10

### Parts of a thrust block

## Auxiliary Steel Wire Windlass

At the forward end of the machinery room there was an auxiliary steel wire windlass. This windlass was also manufactured by Messrs. Napier Brothers. It was a large geared drum which was powered by worm gearing. Around this auxiliary windlass was wound a 3-inch-thick galvanized steel wire rope. This wire rope had two functions. Its first function was to be used with the auxiliary 15-ton anchor in the forward anchor well of the forecastle head. The second function was for the steel wire to be used in the event that the ship was disabled and had to be towed by another ship. The windlass had a brake which was like the brakes on the windlass drums on the forecastle. Once engaged, the force of the load determined the level of braking. The greater the force, the tighter the brake was applied.

### Conclusion

This article was written to explain and illustrate the equipment on “C” (shelter) deck forward which drove the equipment on the forecastle deck which was directly overhead. In the drawings, some structures were eliminated to provide more clarity. Some of the individual pieces of equipment were explained and illustrated.